

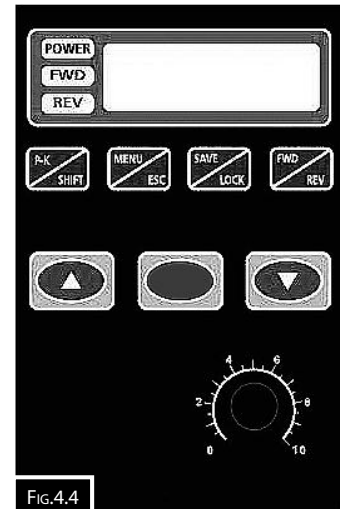

OPERATION MANUAL

NOTE: The AC motor fitted to this machine, is an electronic power device. For safety reasons please note the paragraphs containing **Caution** and **Warning** symbols in this section. They are important safety precautions to observe when, transporting, installing, and when operating and servicing the AC unit.

NOTE: The parameters for the AC inverter motor have been set at the factory and should not need to be touched. If changes need to be made they should be only be changed by a Hafco technician



WARNING

- Do Not:** Touch the PCB or components on the PCB (printed circuit board) before the charging indicator light has gone out.
- Do Not:** Attempt to wire or check the circuitry, or component signals on the PCB when the power is switched ON.
- Do Not:** Attempt to disassemble or modify internal circuitry, wiring or components of the inverter.
- Do Not:** Use the machine if the earthing cable is disconnect from the inverter and the machine. The earthing cable must be connected at all time when being used.

CAUTION

- Do Not:** Attempt to perform dielectric strength tests to the internal components of the inverter unit. There are sensitive semi-conductor devices that are vulnerable to high voltage in the inverter
- Do Not:** Connect the output terminals (T1), (T2) and (T3) to the AC power unit.
- Do Not:** Make contact between the inverter with the primary PCB board. The CMOS IC is Vulnerable to static electrical charges.

SPARE PARTS

The following section covers the spare parts diagrams and lists that were current at the time this manual was originally printed. Due to continuous improvements of the machine, changes may be made at any time without notification.

HOW TO ORDER SPARE PARTS

1. Have your machines model number, serial number & date of manufacture on hand, these can be found on the specification plate mounted on the machine
2. A scanned copy of your parts list/diagram with required spare part/s identified
3. Go to www.machineryhouse.com.au/contactus and fill out the enquiry form attaching a copy of scanned parts list.



OPERATION MANUAL

SPARE PARTS DIAGRAM MBR-610

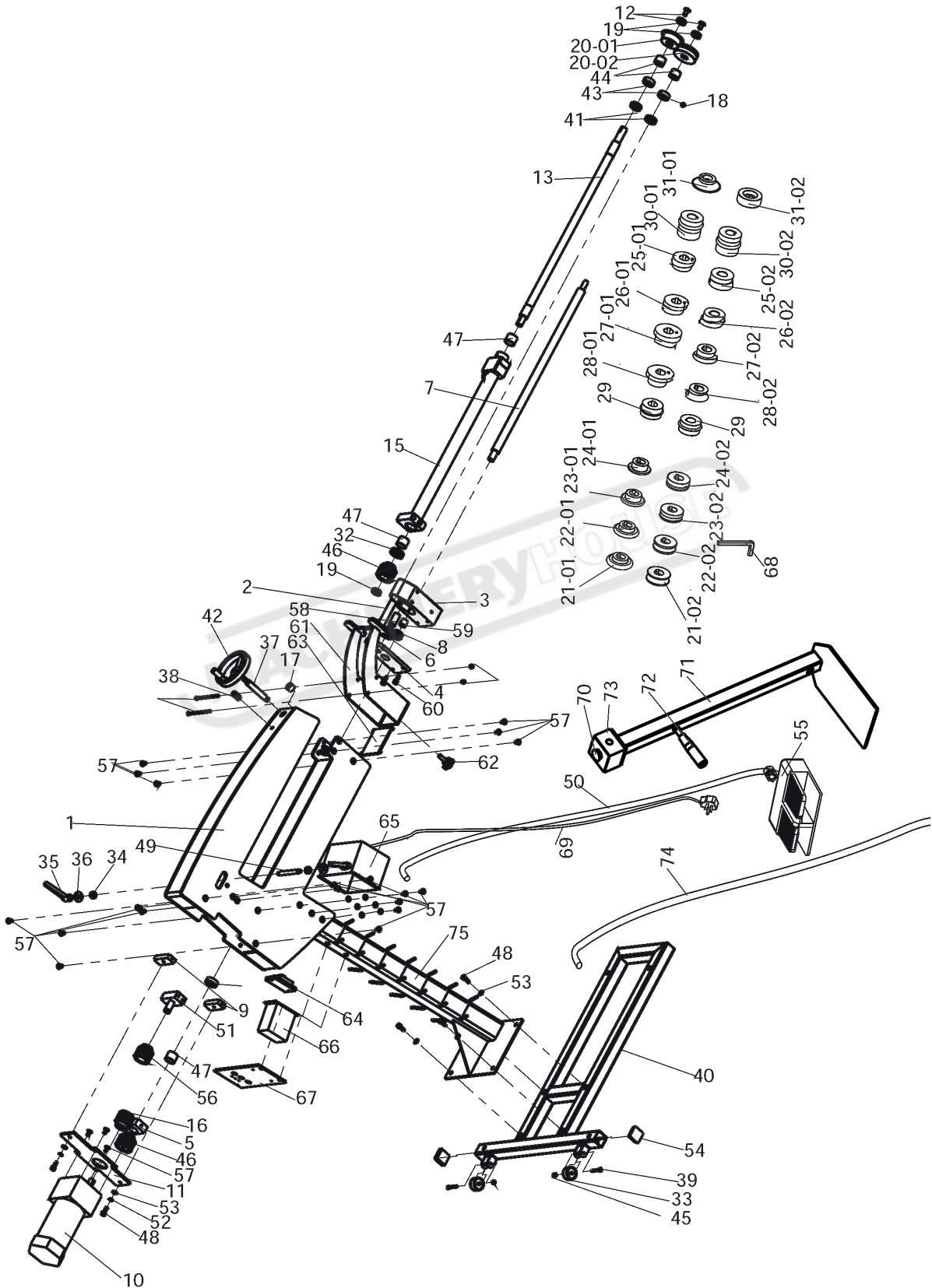



OPERATION MANUAL

SPARE PARTS LIST MBR-610

Part No.	Description	Qty.	Part No.	Description	Qty.
1	Frame for MBR-610	1	33	Wheel	2
2	Gear	1	34	Washer	2
3	Shaft Seat	1	35	Lock Handle	2
4	Shaft Seat Cover	1	36	Washer	2
5	Shaft Seat	1	37	Threaded Rod	1
6	Gear T21m2	1	38	Long Nut M6	1
7	Driving Shaft	1	39	Bolt M6X40	2
8	Gear T14m2	1	40	Stand	1
9	Plate	2	41	Bearing 51104	2
10	Motor	1	42	Handwheel	1
11	Square Plate	1	43	Collar	2
12	Screw M10X20	2	44	Spacer	2
13	Upper Shaft	1	45	Nut M6	2
14	Bushing	2	46	Gear T25m2	2
15	Upper Shaft Bushing	1	47	Bushing	3
16	Gear T23m2	1	48	Screw M8X20	12
17	Pressing Clamp	1	49	Shaft	1
18	Screw M8X8	6	50	Foot Switch Cable	1
19	Fixing Washer	3	51	Base Fixing Gear	1
20-01	Bead Roller Die 5/32"A	1	52	Spring Washer 8mm	12
20-02	Bead Roller Die 5/32"B	1	53	Washer 8mm	12
21-01	Bead Roller Die 1/4"A	1	54	Casing Cap	2
21-02	Bead Roller Die 1/4"B	1	55	Foot Switch	1
22-01	Bead Roller Die 3/8"A	1	56	Gear T23m2	1
22-02	Bead Roller Die 3/8"B	1	57	Screw M8X16	20
23-01	Bead Roller Die 15/32"A	1	58	Shaft	1
23-02	Bead Roller Die 15/32"B	1	59	Bushing	1
24-01	Bead Roller Die 19/32"A	1	60	Screw M6X20	4
24-02	Bead Roller Die 19/32"B	1	61	Guide Fence	1
25-01	Flange Roller Die	1	62	Knob	1
25-02	Flange Roller Die	1	63	Plate	1
26-01	Flange Roller Die 1/8"A	1	64	Safe Switch	1
26-02	Flange Roller Die 1/8"B	1	65	Switch Box	1
27-01	Flange Roller Die 1/4"A	1	66	Speed Change Device	1
27-02	Flange Roller Die 1/4"B	1	67	Box	1
28-01	Flange Roller Die 3/8"A	1	68	Hex Key Wrench 6mm	1
28-02	Flange Roller Die 3/8"B	1	69	Power Cable	1
29	Shearing Die	2	70	Emergency Stop	1
30-01	Ogee Beading Die A	1	71	Stand	1
30-02	Ogee Beading Die B	1	72	Handle	1
31-01	Wiring Die A	1	73	Emergency Stop Box	1
31-02	Wiring Die B	1	74	PVC Coated Steel Conduit	1
32	Bearing 51105	2	75	Leg	1



OPERATION MANUAL

SPARE PARTS DIAGRAM MBR-1070

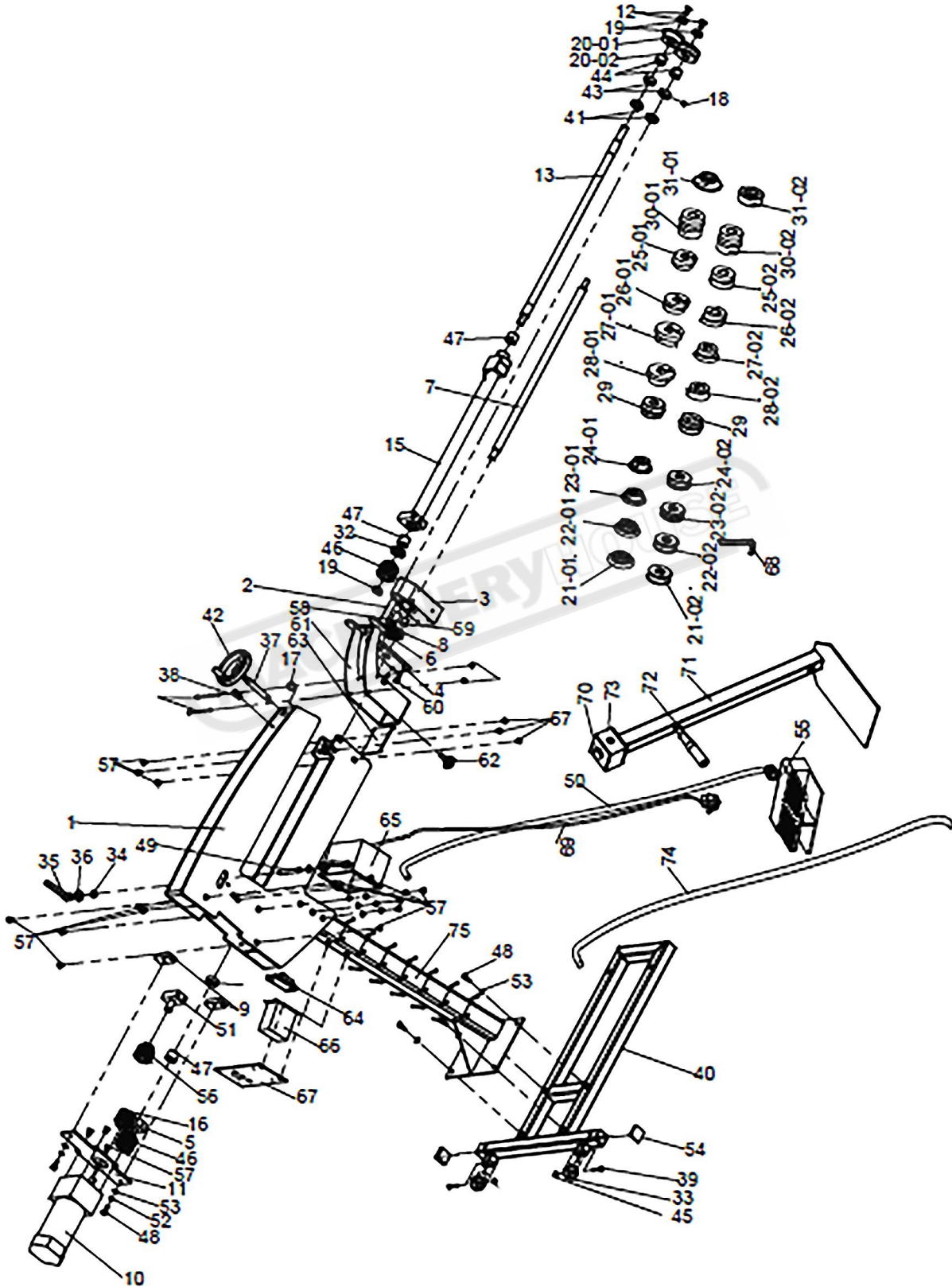



OPERATION MANUAL

SPARE PARTS LIST MBR-1070

Part No.	Description	Qty.	Part No.	Description	Qty.
1	Frame For MBR-1070	1	33	Wheel	2
2	Gear	1	34	Washer	2
3	Shaft Seat	1	35	Lock Handle	2
4	Shaft Seat Cover	1	36	Washer	2
5	Shaft Seat	1	37	Threaded Rod	1
6	Gear T21m2	1	38	Long Nut M6	1
7	Driving Shaft	1	39	Bolt M6X40	2
8	Gear T14m2	1	40	Stand	1
9	Plate	2	41	Bearing 51104	2
10	Motor	1	42	Handwheel	1
11	Square Plate	1	43	Collar	2
12	Screw M10X20	2	44	Spacer	2
13	Upper Shaft	1	45	Nut M6	2
14	Bushing	2	46	Gear T25m2	2
15	Upper Shaft Bushing	1	47	Bushing	3
16	Gear T23m2	1	48	Screw M8X20	12
17	Pressing Clamp	1	49	Shaft	1
18	Screw M8X8	6	50	Foot Switch Cable	1
19	Fixing Washer	3	51	Base Fixing Gear	1
20-01	Bead Roller Die 5/32"A	1	52	Spring Washer 8mm	12
20-02	Bead Roller Die 5/32"B	1	53	Washer 8mm	12
21-01	Bead Roller Die 1/4"A	1	54	Casing Cap	2
21-02	Bead Roller Die 1/4"B	1	55	Foot Switch	1
22-01	Bead Roller Die 3/8"A	1	56	Gear T23m2	1
22-02	Bead Roller Die 3/8"B	1	57	Screw M8X16	20
23-01	Bead Roller Die 15/32"A	1	58	Shaft	1
23-02	Bead Roller Die 15/32"B	1	59	Bushing	1
24-01	Bead Roller Die 19/32"A	1	60	Screw M6X20	4
24-02	Bead Roller Die 19/32"B	1	61	Guide Fence	1
25-01	Flange Roller Die	1	62	Knob	1
25-02	Flange Roller Die	1	63	Plate	1
26-01	Flange Roller Die 1/8"A	1	64	Safe Switch	1
26-02	Flange Roller Die 1/8"B	1	65	Switch Box	1
27-01	Flange Roller Die 1/4"A	1	66	Speed Change Device	1
27-02	Flange Roller Die 1/4"B	1	67	Box	1
28-01	Flange Roller Die 3/8"A	1	68	Hex Key Wrench 6mm	1
28-02	Flange Roller Die 3/8"B	1	69	Power Cable	1
29	Shearing Die	2	70	Emergency Stop	1
30-01	Ogee Beading Die A	1	71	Stand	1
30-02	Ogee Beading Die B	1	72	Handle	1
31-01	Wiring Die A	1	73	Emergency Stop Box	1
31-02	Wiring Die B	1	74	PVC Coated Steel Conduit	1
32	Bearing 51105	2	75	Leg	1